

Street Lamps Explosion-proof Street Lamps

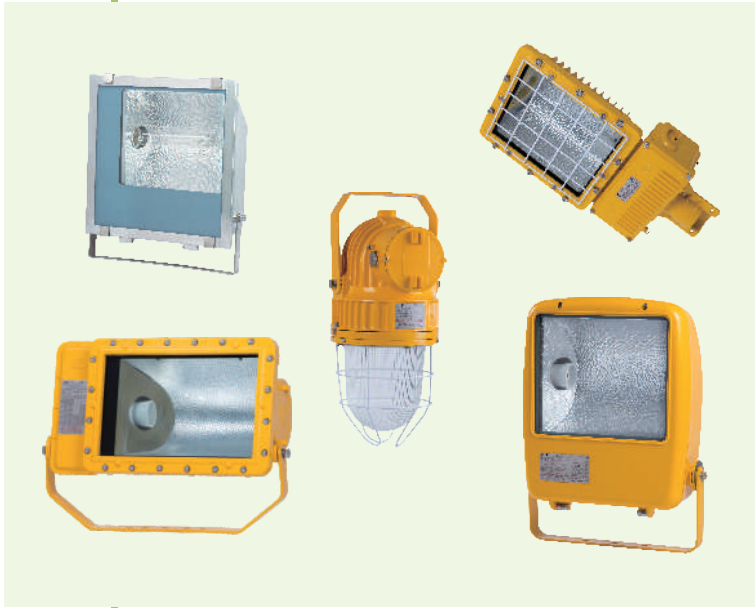

BAT53-250, BAT53-400, BAT85-400 Series
HRD91-250, HRD91-400 Series
BDD91-150, BDD91-250, BDD91-400 Series
BAT86 Series, BnT81 Series, HRT81 Series
Explosion-proof Street Lamps

- ◆ Explosion protection to
 - CENELEC
 - IEC
 - NEC
 - ◆ Can be used in
 - Zone 1 and Zone 2
 - Zone 21 and Zone 22
 - ◆ Please refer to mounting schematic diagram to select right lamp and mounting types on request of job site.
 - ◆ Please refer to this catalogue for detailed technical data and ordering information of each light fitting.
- Note: If BAT53-250 type street lamp is required, please specify when ordering.
- ◆ The street lamp is supplied without pole; please specify when ordering.

Mounting schematic diagram of bent arm type street lamp

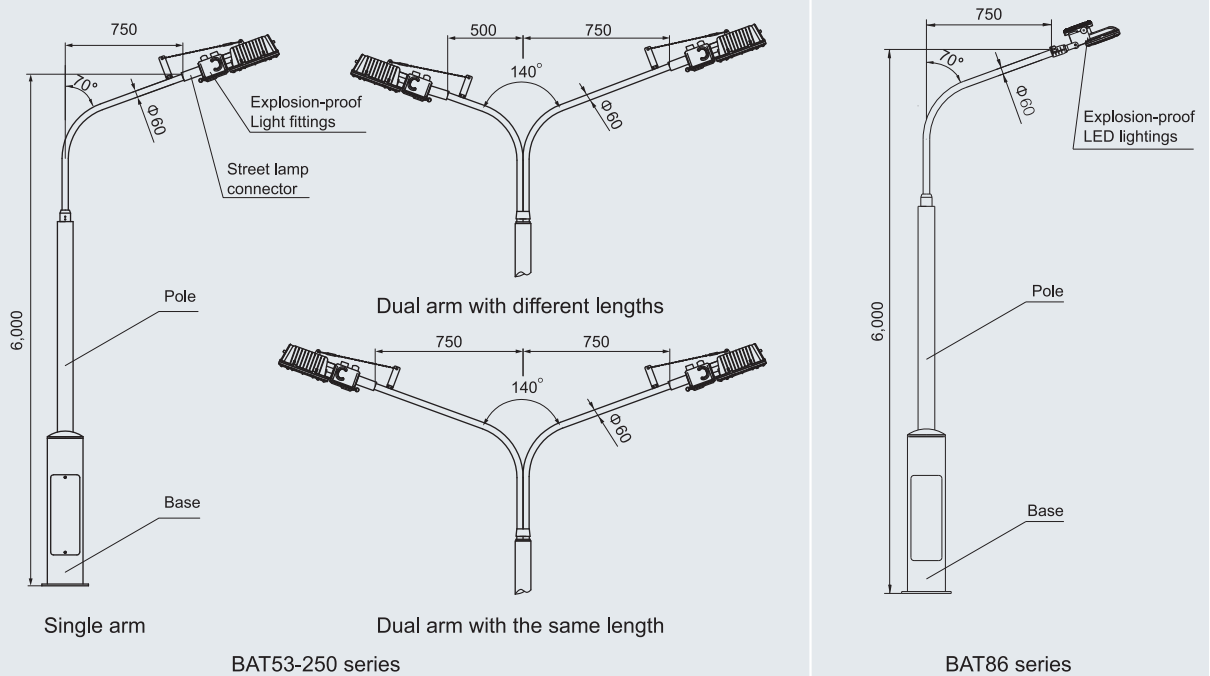

Zones 1&2; 21&22

Street Lamps Explosion-proof Street Lamps

Mounting schematic diagram of platform type street lamp

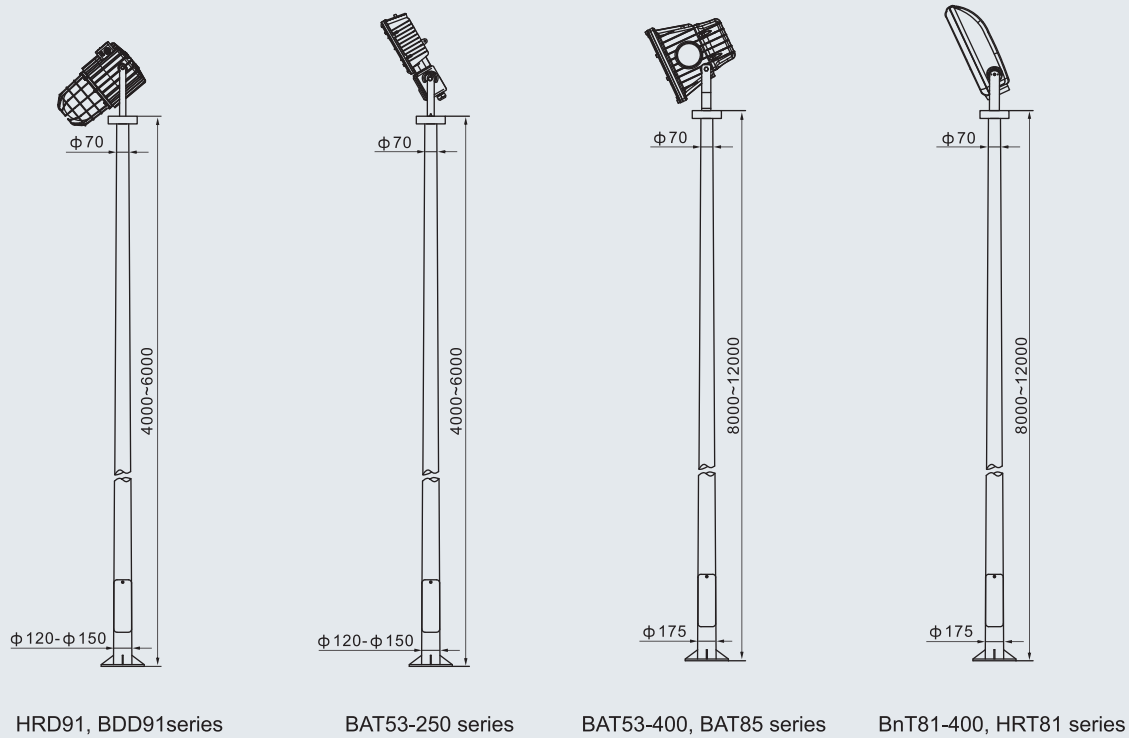

Reference diagram of street lamp mounting base

