

FSZD 系列航空障碍灯

Series Aviation flash obstruction light



Waterproof



Dustproof



Corrosionproof

Weatherproof Light Fittings
防水防尘防腐灯具系列



◆ 型号规格含义/Catalogue number logic

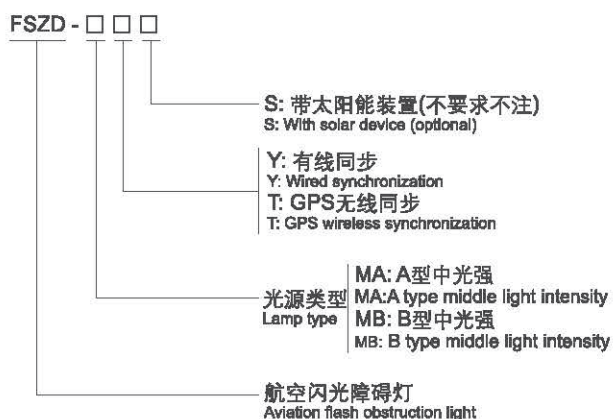

◆ 产品特点/Product features

- ◇ 铝合金压铸壳体，表面高压静电喷塑；
- ◇ PC透明罩、耐腐蚀、抗UV、抗冲击；
- ◇ 控制电路抗冲击能力强、带有防浪涌保护装置，能适用于恶劣的工作环境；
- ◇ 配置集成芯片，具有多种保护电路，可实现多合灯具的同步闪烁；
- ◇ 密封材料：防水密封圈；
- ◇ 可订制功能：故障报警输出功能/GPS同步功能/同步线同步功能/配合专用控制箱可实现远程监控；
- ◇ 可订制主备灯故障切换灯具；
- ◇ 可实现太阳能供电；
- ◇ 防腐等级：WF1、WF2(可选)。
- ◇ Die-casting aluminum alloy enclosure, high-voltage electrostatic powder coated surface.
- ◇ PC transparent cover, corrosion resistance, UV resistance, impact resistance.
- ◇ Strong shock resistance capacity of control circuit, with surge protection device, applicable to severe working environment.
- ◇ Allocate integrated chip, with multiple protection circuit, can realize flash synchronization of multiple light fittings.
- ◇ Sealing material: waterproof seal ring.
- ◇ Customized function: failure warning output function/ GPS synchronization function/equipped with dedicated control box can realize remote control.
- ◇ Can customize Main and spare light fittings disturbance switching to light fittings.
- ◇ Can realize solar energy power supply.
- ◇ Corrosion-proof: WF1, WF2 (Optional).

◆ 技术参数/Technical parameters

参考标准 Reference standards	FSZD-MA(中光强A型) FSZD-MA (Medium-intensity Type A)	FSZD-MB(中光强B型) FSZD-MB (Medium-intensity Type B)
	ICAO-Type A; FAA L-865	ICAO-Type B; FAA L-864
额定电压 Rated voltage	100V~240V AC, 50Hz/60Hz; 48V DC; 24V DC (可定制/Optional)	
环境温度 Ambient temperature	-40℃~+60℃	
防护等级 Degree of protection	IP66	
平均功耗 Average power dissipation	15W(晚上/Night) / 30W(白天/Daytime)	20W
峰值光强 Peak light intensity	2000cd(晚上/Night) 20000cd(白天/Daytime)	2000cd
闪光频率 Flash rate	40FPM(20~60 FPM can be customized 可定制/Optional)	20FPM(20~60 FPM可定制/Optional)
发光颜色 Lighting color	白色/White (其它颜色可订制/Othercolor can be ordered)	红色/Red
发光角度 Beam angle	垂直方向3° / Vertical direction 3° 水平方向360° / Horizontal direction 360°	垂直方向3° / Vertical direction 3° 水平方向360° / Horizontal direction 360°
光控开关灵敏度 Light control switch sensitivity	50/500Lux	50Lux
灯具重量 Weight of Light fitting	6kg	5.5kg



Weatherproof Light Fittings
防水防尘防腐灯具系列

◆ 外形及安装举例/Outline and mounting type (mm)

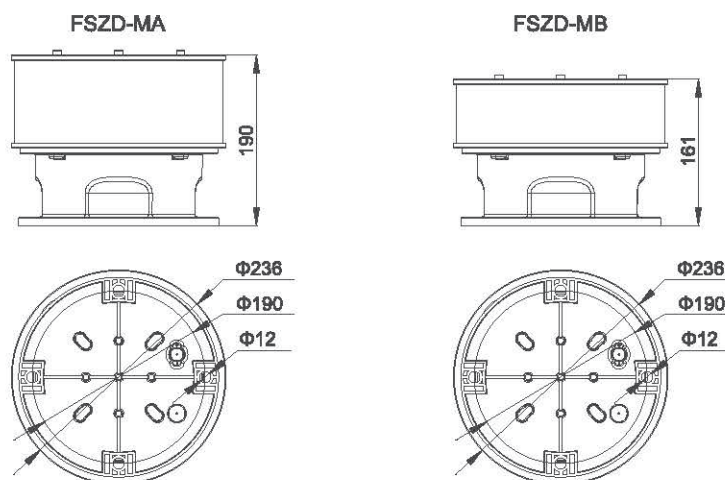

◆ 订货须知/Ordering Information

- ◇ 注明执行标准、工作电压、环境温度；
- ◇ 按照产品型号规格说明逐条选择，例如：FSZD-MA Y表示为中光强A型航空障碍灯，有线同步。
- ◇ Specify the executive standard, working voltage, environment temperature.
- ◇ Follow the product catalogue number logic for selection. For example:
FSZD-MA Y means middle light intensity A type aviation obstruction light, wired synchronization.

FSZD 系列航空障碍灯

Series Aviation flash obstruction light



Waterproof



Dustproof



Corrosionproof

Weatherproof Light Fittings
防水防尘防腐灯具系列

◆ 技术参数/Technical parameters

名称 Mode	航空障碍灯控制箱 Aviation obstruction light control box
控制航空障碍灯数量 Control quantity for Aviation Obstruction Lights	< 24个(pcs)
额定电压 Rated voltage	100V~240V AC(可选其他电压, 48V DC, 24V DC等) 100V~240V AC (Option other voltage, 48V DC, 24V DC, etc)
环境温度 Ambient temperature	-50℃~+60℃
防护等级 Degree of protection	IP66
功耗 Power consumption	< 10W
最大负载 Max load	5KW
外壳材料 Enclosure material	SUS304不锈钢(可选316材料) SUS304 Stainless steel(Option 316 material)
工作方式 Working way	晚上或全天 At night or all day
灯具重量 Wiegth of Light fitting	7.5kg

◆ 产品特点/Product features

- ◇ 强抗腐蚀、抗冲击保护功能;
- ◇ 304不锈钢材料;
- ◇ 监控所有灯的光工作状态;
- ◇ 使用LED指示灯可以直接显示光工作;
- ◇ 有过载保护功能。

- ◇ Strong corrosion-protection and impact-protection function.
- ◇ 304 Stainless Steel material.
- ◇ Monitoring working condition of all lights.
- ◇ Using LED indicator light can display directly light working.
- ◇ Having surge-protection function.



◆ 功能描述/Function

- ◇ 控制箱有一个光控探头, 可通过光控探头控制多个航空障碍灯自动工作。
- ◇ 控制箱可以让多个航空障碍灯同步闪烁。
- ◇ 控制箱具有自动和手动, 浪涌保护和冲击保护功能。
- ◇ 该控制箱具有故障报警功能和远程监控功能。当多个航空障碍灯之一发生故障时, 控制箱将通过相关的LED指示灯亮起来显示报警状态控制单元通过干接点向控制箱输出报警信号。

- ◇ Control box has one light-operated probe, can let multiple Aviation Obstruction Lights work automatically through light-operated probe.
- ◇ Control box can let multiple Aviation Obstruction Light flash sequence synchronization.
- ◇ Control box has Auto & Manual, Surge-protection and impact protection function.
- ◇ This control box has fault alarm function and remote monitoring function. When one of multiple Aviation Obstruction Lights has fault, controller will display alarm state by relevant LED indicator light on control unit and output alarm signal to control box by dry contact.



Weatherproof Light Fittings
防水防尘防腐灯具系列

◆ 外形及安装举例/Outline and mounting type (mm)

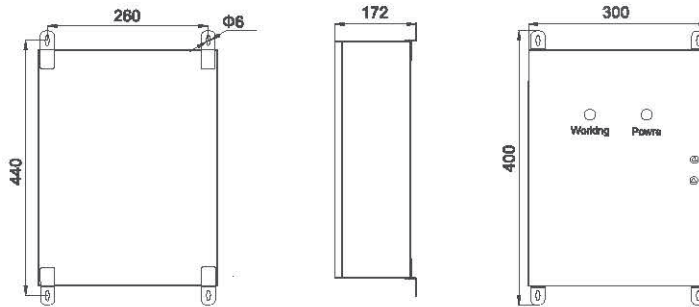

◆ 有线同步连接示意图/Wired synchronous connection schematic diagram

导线颜色/Wire colour

- ① 灰色线/Grey wire
- ② 棕色线/Brown wire
- ③ 黑色线/Black wire
- ④ 黄绿色线/Yellow green wire

无外部同步控制箱
Without external synchronous control box

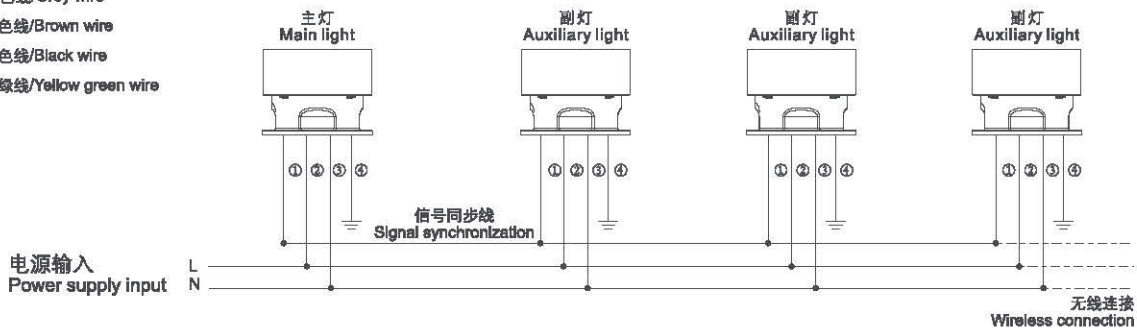

导线颜色/Wire colour

- ① 灰色线/Grey wire
- ② 棕色线/Brown wire
- ③ 黑色线/Black wire
- ④ 黄绿色线/Yellow green wire
- ⑤ 蓝色线/Blue wire

带外部同步控制箱
With external synchronous control box

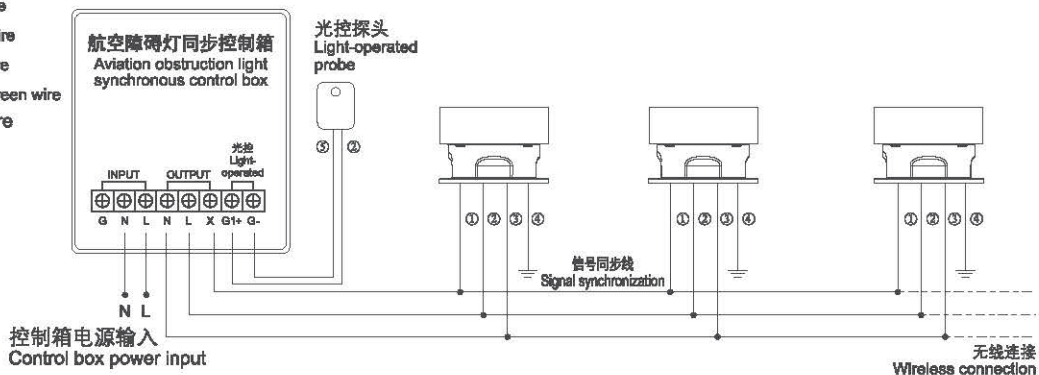

◆ 注意事项/Attention

- ◇ 使用前请确保电源电压与标示电压相同;
- ◇ 在产品工作的时候, 请勿打开灯体任何部分, 防止发生危险;
- ◇ 请勿水平方向直视灯具, 以免损伤眼睛。
- ◇ Pay attention to ensure power voltage and mark are the same before using.
- ◇ When products are working, please do not open any part of light, for fear of danger.
- ◇ Please do not look straight to light in horizontal direction, for fear of eyes injury.