



Waterproof



Dustproof



Corrosionproof

| | | | |
|----|-----|----|------|
| GB | IEC | EN | GOST |
|----|-----|----|------|

型号规格含义 Nomenclature



订货须知 Ordering Information

- ◆ 按照产品型号规格说明逐条选择，
例如：灯杆高度、灯杆形式、灯具数量、灯具型号、灯具功率，以及灯盘样式、控制方式、执行标准形式(如中国标准、国际标准、欧盟标准、北美标准)等；
 - ◆ 由于高杆灯装置是一项涉及机械、电气、光学、土建结构学的复杂工程，在订货时请与我公司工程技术人员联系制作具体最佳方案；
 - ◆ 所有高杆灯的灯具已配相应镇流器及电容，光源用户自备；
 - ◆ 所有高杆灯地脚螺栓用户自备，我公司可提供基础参考示意图。
- ◆ Follow the product nomenclature for selection.
For example: pole height, pole type, number of light fitting, type of light fitting, power, lamp panel, control mode, executive standard form (such as Chinese National standard, International standard, European standard and American standard)etc.
 - ◆ The high pole lamp is a complex project involving mechanical, electrical, optical, and civil engineering and structure, so please contact with our engineering and technical personnel to make preferred plan.
 - ◆ All high-pole lamps are provided with corresponding ballast and capacitors, the lamp source shall be prepared by user.
 - ◆ All anchor bolts of high-pole lamps are prepared by users, and the schematic diagram is provided for reference.

灯具类型 High pole lamps

| 灯具型号 Type | 灯具名称 Name | 防护等级 Degree of protection |
|--------------|---|------------------------------|
| FAT-L | 防水防尘防腐泛光灯 Weatherproof floodlight | IP65/IP66 |
| HRFT-E | 防水防尘防腐LED泛光灯 Weatherproof LED floodlights | IP66 |

产品特点 Product features

- ◆ 执行标准：
GB50017《钢结构设计规范》、GBJ135《高耸结构设计规范》、GB50011《建筑抗震设计规范》、GB 50007《建筑地基基础设计规范》、CJ/T 3076《高杆照明设施技术条件》、GB 699《优质碳素结构钢技术条件》、GB/T13912《金属覆盖层钢铁制件热浸镀锌技术要求》；
- ◆ 本公司高杆灯结构紧凑、整体牢固、组装、维修便利，升降系统和电器系统工作可靠，配光合理，照度均匀，且照明范围可达3000多平方米；高杆灯灯盘造型可按用户意愿或工程需要设计成多种结构形式。
- ◆ 灯杆
 - 1) 灯杆由优质低碳钢板经剪制、折弯、自动焊接成型，可按要求制作不锈钢灯杆；
 - 2) 高杆灯的全部钢结构件均进行热镀锌及表面喷塑处理，使所有内外壁表面均获得妥善保护以延长使用寿命和节约维护费用；
 - 3) 灯杆底部开有电器门，内置自动、手动升降系统和电器控制系统。门上备有特制的门锁，可有效避免非工作人员开启。
- ◆ 电器控制系统
 - 1) 电器控制及保护装置都安装固定于灯杆底部的控制箱内，备有照明控制及电机控制线路；
 - 2) 采用手动控制主令控制器，实现远距离控制升降(约5米)；
 - 3) 双回路电力电缆供电，可实现全负荷照明和部分照明，具有手控、光控及电脑时间控制等多种方式，以满足用户的不同需求；
 - 4) 采用拖缆方式供电，控制箱和照明电缆采用特制的具有锁定装置的专用插件连接。
- ◆ 自动、手动升降系统
由电机、蜗轮蜗杆、卷扬机等部分组成。具有自锁性能的蜗轮蜗杆传动机构，可以使灯盘在任何位置停止，并设置过扭矩保护，具有自动、手动操作功能。
- ◆ 导向及制动系统(选配)
此系统在灯盘正常上升和下降过程中起导向作用，一旦钢丝绳发生断裂时，系统起制动保护，防止灯盘坠落的作用。
- ◆ 防雷接地装置
高杆灯必须设置专用接地装置，接地电阻不大于10欧姆。
- ◆ Executive standards:
GB50017 Code for Design of Steel Structures, GBJ135 High Rise Structure Design Specification, GB50011 Code of Aseismic Design of Buildings, GB 50007 Code for Design of Building Foundation, CJ/T3076 Technical Conditions of High Pole Lighting Facilities, GB699 High Quality Carbon Structure Steel Technical Conditions, GB/T13912 Metal Covering Layer Steel Work Pieces Hot Dip Galvanizing Technology Requirements.
- ◆ The high pole lamp is of compact and firm structure, easy assembly and maintenance. Lift systems and electrical systems can work reliably, with reasonable light distribution, uniform illumination, and lighting range up to more than 3000 square meters. Lamp panel style can be made upon users' request or based on engineering needs.
- ◆ Lamp pole
 - 1) Light pole is made of high-quality low-carbon steel plate through shear, bending, and automatic welding. Stainless steel light poles can be made upon request.
 - 2) All the steel components are of hot dip galvanized and powder coated so that all internal and external wall surfaces are protected properly to extend the service life and save maintenance costs.
 - 3) There are electrical door at the bottom of the light pole, with built-in automatic and manual lifting system and electrical control system. A specially designed lock is equipped on the door to effectively avoid being opened by non-staffs.
- ◆ Electrical control system
 - 1) Electrical control and protection devices are installed and fixed inside the control box at the bottom of lamp, equipped with lighting control and motor control circuit.
 - 2) With manual control master controller to achieve remote control of lifting (about 5 meters).
 - 3) Double-loop power cables for power supply, to achieve full load lighting and partial lighting, with a variety of ways for control, such as manual control, light control and computer time control, etc. to meet the needs of different users.
 - 4) Towlines are used for power supply, control box and lighting cables are connected with specific plugs which have special locking device.
- ◆ Automatic and manual lifting system
The system is composed of motor, worm gear, and hoist. Worm gear drive mechanism with self-locking function can make the lamp panel stop at any location, and over torque protection is set, automatic operations and manual operations are available.
- ◆ Guiding and brake system (optional)
This system play a guiding role in the normal rise and fall of lamp panel once the wire rope breaks, this system has brake protection, it can prevent lamp panel from falling.
- ◆ Lightning protection grounding device
The high-pole lamp must have a dedicated grounding device, grounding resistance less than 10 ohms.



FGD 系列防水防尘高杆灯

FGD Series Weatherproof High Pole Lamps

外形及安装举例 Outline and mounting type

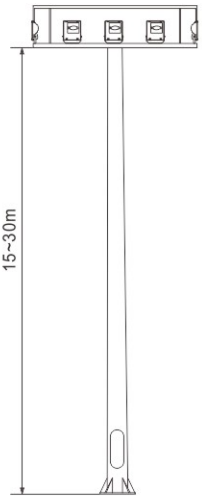
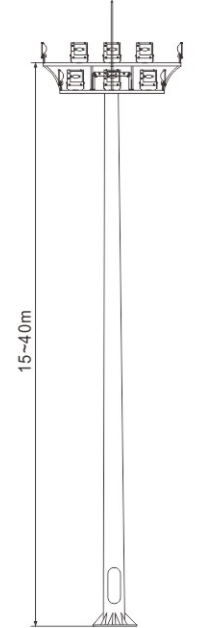
| 形式 Form | 高度(m) Height | 边数 Side number | 底法兰参数 Base flange parameter | | | | | 灯具重量 Lamp weight (kg) | 灯盘重量 Lamp panel weight (kg) |
|---|-----------------|----------------------|---------------------------------|-----------------------------|-----------------------------|----------------------------|----------------------|--------------------------------|--------------------------------------|
| | | | 板厚(mm) Thickness of board | 外径(mm) Outer diameter | 孔距(mm) Pitch of holes | 孔径(mm) Bore diameter | 孔数 Hole number | | |
|  <p>固定式灯杆(A型) Fix type lamp pole (type A)</p> | 15 | 8 | 20 | 700 | 560 | 36 | 8 | 200 | 200 |
| | | 8 | 20 | 700 | 560 | 36 | 8 | 400 | 400 |
| | | 12 | 25 | 700 | 560 | 36 | 12 | 600 | 600 |
| | | 12 | 25 | 780 | 640 | 42 | 12 | 800 | 200-600 |
| | 20 | 12 | 25 | 780 | 640 | 42 | 12 | 200 | 200 |
| | | 12 | 25 | 780 | 640 | 42 | 12 | 400 | 400 |
| | | 12 | 25 | 780 | 640 | 42 | 12 | 600 | 600 |
| | | 12 | 30 | 850 | 710 | 42 | 12 | 800 | 200-600 |
| | 25 | 12 | 30 | 850 | 710 | 42 | 12 | 200 | 200 |
| | | 12 | 30 | 850 | 710 | 42 | 12 | 400 | 400 |
| | | 12 | 30 | 850 | 710 | 42 | 12 | 600 | 600 |
| | | 12 | 35 | 950 | 810 | 48 | 12 | 800 | 200-600 |
| | 30 | 12 | 35 | 950 | 810 | 48 | 12 | 200 | 200 |
| | | 12 | 35 | 950 | 810 | 48 | 12 | 400 | 400 |
| | | 12 | 35 | 950 | 810 | 48 | 12 | 600 | 600 |
| | | 12 | 35 | 1100 | 900 | 56 | 12 | 800 | 200-600 |
|  <p>升降式灯杆(B型) Lift pole (type B)</p> | 15 | 12 | 25 | 850 | 710 | 42 | 12 | 200 | 200 |
| | | 12 | 25 | 850 | 710 | 42 | 12 | 400 | 400 |
| | | 12 | 25 | 850 | 710 | 42 | 12 | 600 | 600 |
| | | 12 | 25 | 850 | 710 | 42 | 12 | 800 | 200-600 |
| | 20 | 12 | 25 | 850 | 710 | 42 | 12 | 200 | 200 |
| | | 12 | 25 | 850 | 710 | 42 | 12 | 400 | 400 |
| | | 12 | 25 | 850 | 710 | 42 | 12 | 600 | 600 |
| | | 12 | 25 | 850 | 710 | 42 | 12 | 800 | 200-600 |
| | 25 | 12 | 30 | 900 | 750 | 48 | 12 | 200 | 200 |
| | | 12 | 30 | 900 | 750 | 48 | 12 | 400 | 400 |
| | | 12 | 30 | 900 | 750 | 48 | 12 | 600 | 600 |
| | | 12 | 30 | 950 | 810 | 48 | 12 | 800 | 200-600 |
| | 30 | 12 | 30 | 950 | 810 | 48 | 12 | 200 | 200 |
| | | 12 | 30 | 950 | 810 | 48 | 12 | 400 | 400 |
| | | 12 | 30 | 950 | 810 | 48 | 12 | 600 | 600 |
| | | 12 | 35 | 1100 | 900 | 56 | 12 | 800 | 200-600 |
| 35 | 12 | 35 | 1100 | 900 | 56 | 12 | 200 | 200 | |
| | 12 | 35 | 1100 | 900 | 56 | 12 | 400 | 400 | |
| | 12 | 35 | 1100 | 900 | 56 | 12 | 600 | 600 | |
| | 12 | 40 | 1200 | 1000 | 56 | 12 | 800 | 200-600 | |
| 40 | 12 | 40 | 1200 | 1000 | 56 | 12 | 400 | 400 | |
| | 12 | 40 | 1200 | 1000 | 56 | 12 | 600 | 600 | |
| | 12 | 40 | 1200 | 1000 | 56 | 12 | 800 | 200-600 | |



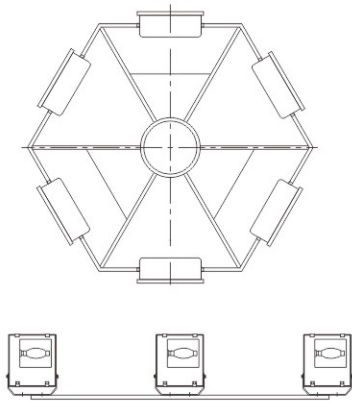

六边形灯盘
Hexagonal lamp panel

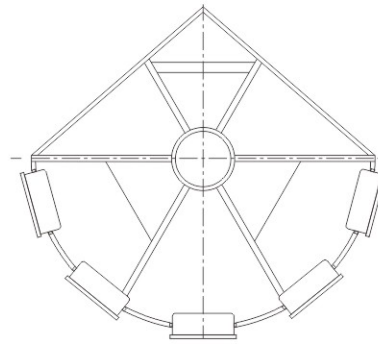

扇形灯盘
Fan-shaped lamp panel

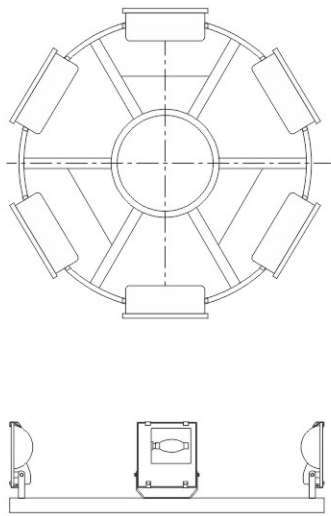

圆形灯盘
Round lamp panel

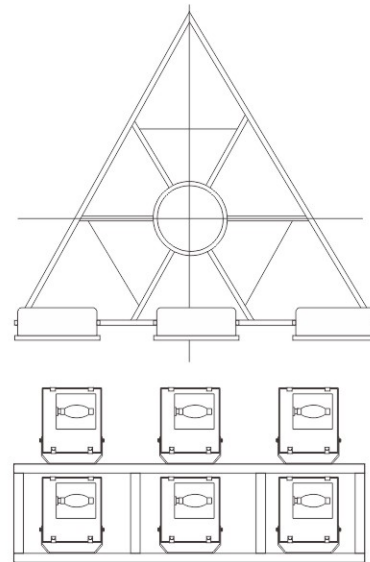

三角形灯盘
Triangular lamp panel



基础参考示意图举例 Schematic diagram of foundation

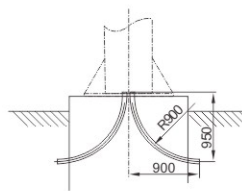
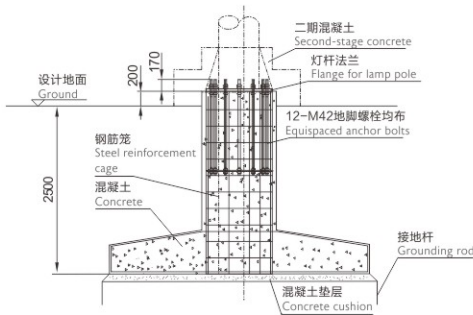

基础内预埋电缆管位置图
Diagram for the position of cable pipe that embedded in the foundation

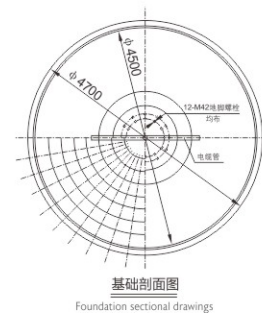

基础剖面图
Foundation sectional drawings

说明:

- ◆ 地基强夯，使承载能力达到12t/m²以上；
- ◆ 基础内预埋电缆管弯曲半径不小于900；
- ◆ 接地电阻不大于10欧姆。

Notes:

- ◆ Foundation is treated by dynamic consolidation resulting in a carrying capacity exceeding 12t/m².
- ◆ The bending radius of embedded cable pipe in the foundation is not less than 900.
- ◆ Grounding resistance is not more than 10 ohms.