

SCS-JK Intelligent AI Video Image Analysis and Warning System WRJK-S/RX Series Fixed-type Explosion-proof Infrared Thermal Imaging Data Analysis Processor (Camera)



- ◆ Explosion protection to
 - CENELEC
 - IEC
- ◆ Can be used in
 - Zone 1 and Zone 2
 - Zone 21 and Zone 22
- ◆ Product features: intelligent control, intelligent monitoring, intelligent communication, intelligent recognition, intelligent analysis, intelligent monitoring.

Product features

- ◆ Fixed-type explosion-proof infrared thermal imaging data analysis processor (camera) features an online infrared thermal imager with front-end temperature measurement technology of 384×288 / 640×480 pixels, offering explosion-proof performance, reliable and stable temperature measurement accuracy, optimized network transmission, high protection rating, rational structure for easy installation, and a comprehensive SDK for convenient secondary development.
- ◆ The front-end lens is optional, it uses a uncooled focal plane detector to capture images and performs all image processing and temperature calculations. It can directly output analog video signals to monitors or view video feeds via web browsers or client software. It supports single-frame or continuous acquisition of raw data for secondary temperature analysis.
- ◆ The product is widely used in industries such as petrochemicals, power generation, scientific research, new energy, inspection and quarantine, and forest fire prevention.



Basic principles of thermal imaging

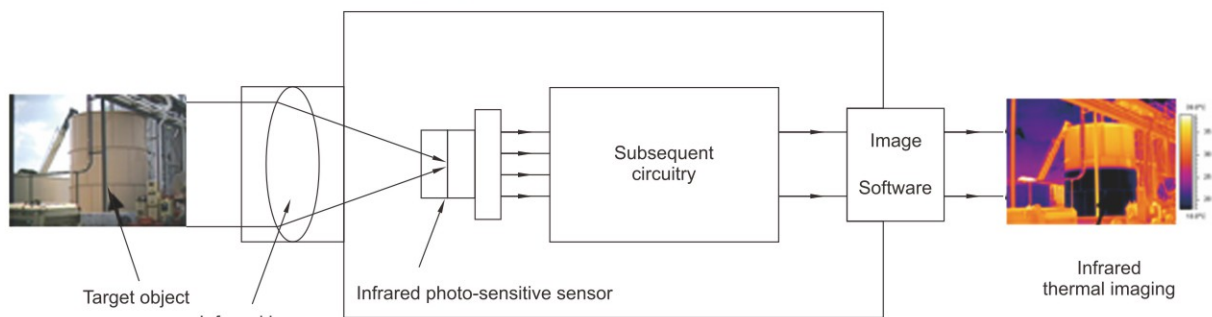

Block diagram of infrared thermal imaging principle

- ◆ In nature, all matter above absolute zero (-273°C) continuously emits electromagnetic waves related to its properties and temperature. This phenomenon is known as thermal radiation.
- ◆ A thermal imaging camera is a device that measures differences in radiation between a target and its background, or between different parts of the target, converts the object's radiated power signals into electrical signals, amplifies them, and then forms a video image.

Zones 1&2; 21&22

SCS-JK Intelligent AI Video Image Analysis and Warning System

WRJK-S/RX Series Fixed-type Explosion-proof Infrared Thermal Imaging Data Analysis Processor (Camera)

Technical data

Fixed-type Explosion-Proof Infrared Thermal Imaging Data Analysis Processor (Camera) WRJK-S/RX

Explosion protection

Global (IECEX)
Gas and dust

IECEX (applied for)
Ex db IIC T6 Gb
Ex tb IIIC T80°C Db

Europe (ATEX)
Gas and dust

ATEX (applied for)
Ex II 2 G Ex db IIC T6 Gb
Ex II 2 D Ex tb IIIC T80°C Db

Certificates

IECEX; ATEX

Conformity to standards

IEC 60079-0, IEC 60079-1, IEC 60079-31, EN 60079-0, EN 60079-1, EN 60079-31

Rated voltage

176-264V AC, 12V DC

Material

304 stainless steel or 316 stainless steel

Communication interface

1 RJ45 10M/100M auto-sensing Ethernet port

Thermal imaging

Sensor type

Vanadium oxide uncooled infrared detector

Pixel size

12 μ m

Response wavelength band

8~14 μ m

Frame rate

25 fps

Pixels

384×288, 640×480 (Optional)

Focal length

10 mm

Field of view

26.4°×19.8°

Temp. Measurement accuracy

±2°C or ±2%

Max. Detection distance for target objects

16 m

Max. Alarm distance for personnel

100 m

Max. Alarm distance for vehicles

300 m

Temp. Measurement range

-20°C~650°C

Max. Fire point detection distance

600 m

Visible light

Sensor type

1/1.8" progressive scan CMOS

Effective pixels

2 million or 4 million pixels

Optical zoom ratio

2x

Aperture value

F 1.8 - F 2.8

Min. Illumination

0.08 Lux (color)

White light illumination distance

15m

Dual-spectrum fusion

Supports fusion of thermal imaging channel with visible light image information to enhance detail in thermal images

Video compression standard

H.265/H.264/MJPEG

Protection rating

IP68(2m/2h)

Temperature range

-40°C~+60°C

Weight

7kg



Dimension drawings (all dimensions in mm) - subject to alteration

